



PROJECT		REF		REV	ITEM CODE	
LOCATION		DATE			PAGE	

SANITARY WARE SPECIFICATION SHEET

Item Descriptions	Stern (Israel) "Green BR" Chrome plated deck mounted sensor faucet with LED ring illumination in AC Supply with 5m wire AC 110-240 Vac 50/60Hz to 9V 0.3A IP68 waterproof switching transformers
Dimensions	L122 x W45 x H230 mm
Model	Green BRE AB 1953
Code Number	225921
Finish	Chrome Plated
Source	Acme Sanitary Ware Co. Ltd Mr. Eric Wong / Mr. Don Yuen
Contact Tel/Fax	(852) 2388-7171 / (852) 2710-8012
E-mail	acme@acmesanitary.com.hk
Website	www.acmesanitary.com.hk

GREEN BRE AB 1953 Ref # 225921
 Touch-free electronic faucet for deck-mounted installations. Activated by a infrared sensor. With LED ring illumination. For cold or premixed water. Filters included. Latching solenoid valve is located above deck inside the product for added vandal protection. Solid brass one-piece construction. Adjustable settings by remote control: sensor range, security time, delay in, delay out, on-off and reset to factory settings.

Application:
 Deck-mounted faucet. Combining an elegant minimalist design with anti-vandal features. Easy installation. Long lasting even in the harshest installation sites. Helps washrooms stay clean and saves water. Prevents cross contamination. Ideal for stadiums, train and bus stations and highway rest stops.

Use:
 Touch-free electronic faucet. The faucet is automatically activated when users place their hands in the sensor range and stops when the users remove their hands.

Illustration/ Drawing

PRODUCT AT A GLANCE	
Installation	Lavatory mounted
Recommended Pressure	0.5-8.0 BAR / 7.0-116 PSI. For a pressure over 8 bar use a pressure reducing valve.
Power Supply	<ul style="list-style-type: none"> External battery box with 9V Alkaline Battery Internal 9V battery. 9V Transformer
Water Saving Options	6 LPM / 1.58 GPM ; 4 LPM / 1 GPM ; 3 LPM / 0.8 GPM 1.89 LPM / 0.5 GPM ; 1.3 LPM 0.35 GPM
Water Supply	Cold or premixed water
Water temperature	Max 70°C
Security Time	90 seconds. Adjustable with Stern's remote control.

ORDERING INFORMATION		OPTIONAL ACCESSORIES	
PRODUCT NAME	PART NUMBER	PRODUCT NAME	PART NUMBER
GREEN AB 1953	225901	Matching Green Soap Dispenser - battery operated	225845
GREEN B AB 1953	225951	Matching Green Soap Dispenser - transformer operated	225840
GREEN E AB 1953	225941		
GREEN BRE AB 1953	225921	Remote Control	07100005

- Installation:**
Lavatory mounted
- Water supply:**
Cold or premixed water (1 inlet)
- Water temperature:**
Max 70 °C
- Operating pressure:**
0.5 - 8.0 bar
- Power source:**
9V transformer
- Stern Soap & Water:**
Green matching soap dispenser

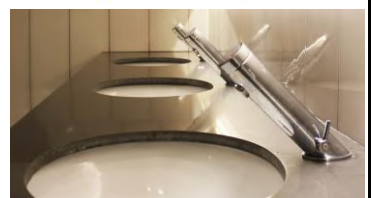

* All information of the above is for the reference only. No prior notice is made if any changes.



SPARE PARTS LIST

Green BRE
(225921)

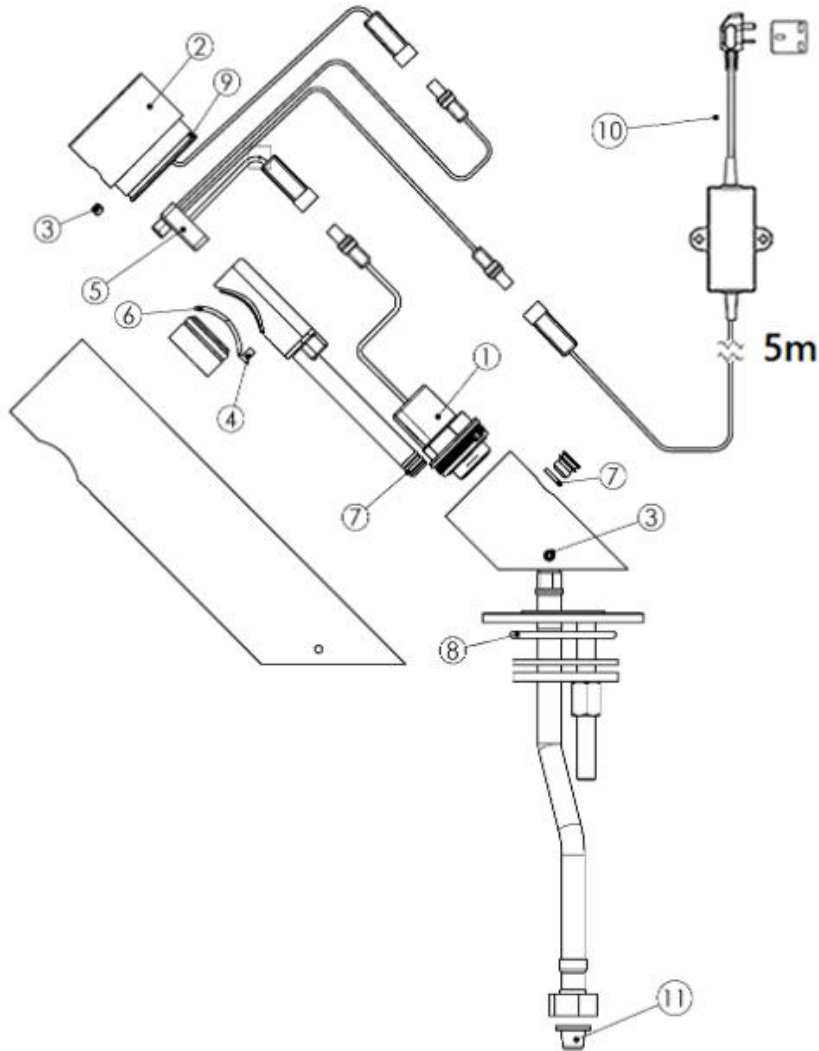

Quantity	Part Number	Description	Cat. No.
	-	Seals and Screws Kit	07210082
1	6	O-ring	
3	7	O-ring	
1	9	O-ring	
1	8	O-ring	
2	3	Screw	
1	4	Screw	
	2	Cover Kit	07270159
	5	Nano Sensor	08004017
	1	Stern Interoperable NS9V1.2WWPC1	07500089
	11	Filter	08530014
	10	Transformer	TBC

Note: In order to locate the relevant spare part, please check the corresponding parts and part number in the drawing. Minimum order quantity will be required.

* All information of the above is for the reference only. No prior notice is made if any changes.



INSTALLATION / INSTALACIÓN

(EN) STEP 1 – PREPARATION FOR MOUNTING THE FAUCET (ES) PASO 1 - PREPARACIÓN PARA EL MONTAJE DEL GRIFO

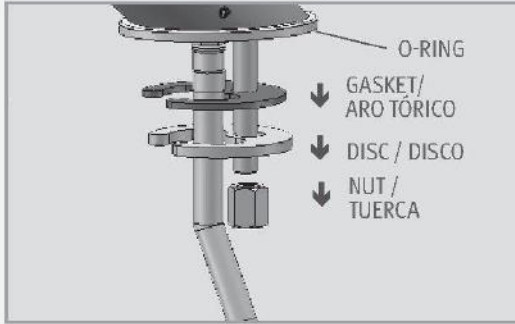
<p>1</p>	<p>(EN) Shut off the water supply.</p> <p>(ES) Cierre el suministro de agua.</p>	
<p>2</p>	<p>(EN) Remove the hexagonal nut, disk, and gasket. Do not remove the O-ring from the escutcheon.</p> <p>(ES) Retire la tuerca hexagonal, el disco y la junta. No retire el anillo torico de la base del grifo.</p>	

(EN) STEP 2 – INSTALLING THE FAUCET (ES) PASO 2 - INSTALACIÓN DEL GRIFO

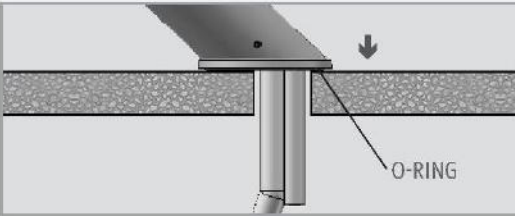
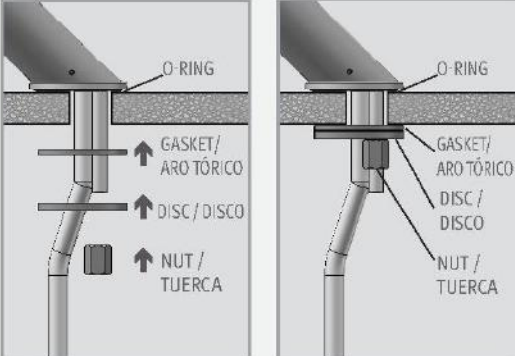
<p>1</p>	<p>(EN) Place the faucet base into the hole in the deck. Ensure that the O-ring is located between the bottom of the faucet and the top of the deck.</p> <p>(ES) Coloque el grifo con el anillo tórico en el orificio del lavabo o encimera. Asegúrese de que el anillo tórico queda situado entre el lavabo o la encimera y la parte inferior del grifo.</p>	
<p>2</p>	<p>(EN) Slide the gasket and disk over the flexible hose and secure the faucet in place by firmly tightening the hexagonal nut onto the threaded rod.</p> <p>(ES) Deslice la junta, el disco y la tuerca hexagonal sobre el tubo flexible y fije el grifo en su sitio enroscando la tuerca con fuerza.</p>	



INSTALLATION / INSTALACIÓN

(EN) STEP 3 – CONNECTING THE WATER SUPPLY (ES) PASO 3 - CONEXIÓN DEL SUMINISTRO DE AGUA

- 1**
- (EN) For Green / Green B/E AB1953**
Connect the flexible pipe to the water supply.
- For Green 1000 B/E AB1953 versions**
Connect the red flexible pipe to the hot water supply and the blue flexible pipe to the cold water supply.
- Para Green / Green B/E AB1953:**
Conecte la tubería flexible a la entrada de agua. Para **Green 1000 B/E AB1953:**
Conecte la tubería flexible roja a la entrada de agua caliente y el tubo flexible azul a la entrada de agua fría.

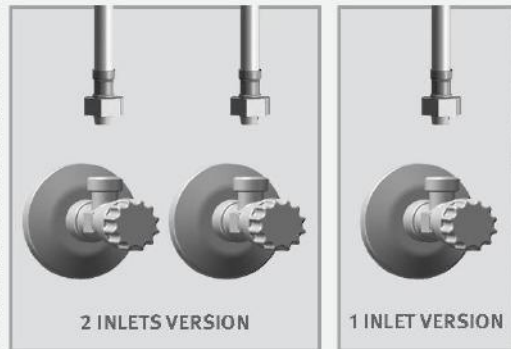

(EN) MAKE SURE THAT THE FILTER(S) IS/ARE INSTALLED BETWEEN THE FLEXIBLE PIPE(S) AND THE SHUT OFF VALVE(S) (ANGLE VALVE) (NOT SUPPLIED).
(ES) ASEGÚRESE DE QUE EL/LOS FILTRO(S) QUEDA(N) INSTALADO(S) ENTRE LA(S) TUBERÍA(S) FLEXIBLE(S) Y LA(S) LLAVE(S) DE PASO (VÁLVULA(S) DE ÁNGULO) (NO SUMINISTRADAS)

- 2**
- (EN)** Turn on the central water supply and the shut-off valves (angle valves) and check for leaks.
- (ES)** Conecte el suministro central de agua y las llaves de paso (válvulas de ángulo) y verifique que no haya fugas.

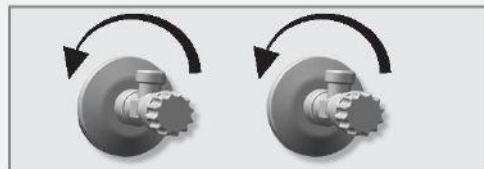

- 3**
- (EN)** Connect the power source.
- (ES)** Conecte la fuente de alimentación.

- 4**
- (EN)** Once the power source is connected, wait 15 seconds to allow the system to set the ideal sensor range. A red LED will flash continuously to indicate this adjustment period. The solenoid valve will open for 1 second to indicate that the ideal sensor range was set.
- (ES)** Una vez conectada la fuente de alimentación, espere 15 segundos para permitir al sistema establecer el rango del sensor idóneo. La luz LED roja parpadeará de forma continua para indicar que se está realizando el ajuste. La válvula solenoide se abrirá durante un segundo para indicar que el rango se ha establecido



- 5**
- (EN)** If the automatically adjusted sensor range is not satisfactory to your purposes, please refer to the section entitled “Settings adjustment”.
- (ES)** Si el rango establecido automáticamente no le satisface, consulte la sección “Configuración de parámetros”.



INSTALLATION / INSTALACIÓN

(EN) STEP 4 – CONNECTING THE POWER SOURCE (ES) PASO 4 - CONEXIÓN DE LA FUENTE DE ALIMENTACIÓN

(EN) This product includes a self adjusting sensor. The ideal sensor range for the specific location will be set automatically.

(EN) Este producto incluye un sensor autoadaptativo. Se establecerá de forma automática el rango ideal del sensor para su ubicación concreta.

1

(EN) Important: Check that no objects are in front of the sensor besides the washbasin.

(ES) Importante: Compruebe que no haya objetos delante del sensor aparte del lavabo.

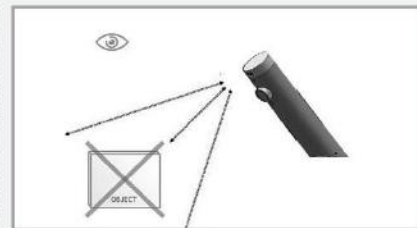

2

(EN) Now, remove the protecting sticker that covers the sensor.

(ES) Retire la pegatina protectora que cubre el sensor.



(EN) If your model is Green or Green 1000:

Wait about 30 seconds in order to allow the system to set the ideal sensor range. After the self adjustment has taken place the the solenoid valve will open and close for 1 second and a small amount of water will be leave the spout. Then the product will be ready for use.

(ES) Si su modelo es Green B o Green 1000 B:

Espere unos 30 segundos para permitir al sistema establecer el rango idóneo del sensor. Una vez completado el autoajuste, la válvula solenoide se abrirá durante un segundo y se cerrará y saldrá una pequeña cantidad de agua por el caño. En ese momento el producto estará listo para su uso.



3

(EN) If your model is Green B or Green 1000 B:

Install the battery box on the wall underneath the sink using the two sided adhesive foam tape. The cable connection must point down. (You can use an optional extension cable in order to assemble the battery box up to 10ft. away from the sink.)

(ES) Si su modelo es Green B o Green 1000 B:

Instale la caja de pilas sobre la pared debajo del lavabo, utilizando la cinta adhesiva acolchada de dos caras. La conexión del cable debe apuntar hacia abajo (puede utilizar la extensión de cable opcional para instalar la caja de pilas a una distancia de hasta 3 metros (10 ft) del lavabo).

(EN) If your model is Green E or Green 1000 E: Plug the transformer into the electricity socket and connect the connectors.

(ES) Si su modelo es Green E o Green 1000 E: Enchufe el transformador en la toma de corriente y conecte los conectores.



INSTALLATION / INSTALACIÓN

STEP 4 – CONNECTING THE POWER SOURCE PASO 4 - CONEXIÓN DE LA FUENTE DE ALIMENTACIÓN

4

(EN) Wait about 5 seconds in order to allow the system to set the ideal sensor range. After the self adjustment has taken place the solenoid valve will open and close for 1 second and a small amount of water will be leave the spout. Then the product will be ready for use.

(ES) Espere unos 5 segundos para permitir que el sistema establezca el rango ideal del sensor. Una vez finalizado el autoajuste, la válvula solenoide se abrirá durante un segundo y se cerrará, y una pequeña cantidad de agua saldrá por el caño. El producto estará listo para su uso.



ABOUT/ APROX.

5

SECONDS/ SEGUNDOS

5

(EN) If the obtained range is unsatisfactory, refer to the section entitled “Settings adjustment”.

(ES) Si el rango obtenido no es satisfactorio, consulte la sección titulada “Configuración de parámetros”.

(EN) NOTE: This model includes a special aerator that allows you to adjust the water stream direction on site in order to prevent water splashing if needed. To change the angle of the water stream, simply move the adjustable tilting plate by pressing it smoothly.

ATTENTION! the aerator is tightened to prevent removal by hand.

(ES) NOTA: Este grifo incluye un aireador especial que permite al usuario ajustar in situ la dirección del chorro de agua en caso necesario, para evitar salpicaduras. Para modificar el ángulo del chorro de agua, simplemente mueva la lámina basculante ajustable con una ligera presión.

¡ATENCIÓN! El aireador está fuertemente apretado para evitar que se pueda extraer manualmente.





TROUBLESHOOTING

PROBLEM	INDICATOR	CAUSE	SOLUTION
No water coming out of the faucet:	1. Sensor flashes continuously when user's hands are within the sensor's range.	Low battery.	Replace battery
	2. LED in the sensor does not flash once when user's hands are within the sensor's range.	1. Range is too short.	Increase the range
		2. Range is too long.	Decrease the range
		3. Battery is completely used up	The battery must be replaced.
		4. Unit is in "Security Mode"*	
3. LED in the sensor flashes once when user's hands are within the sensor's range.	5. Sensor is picking up reflections from the washbasin or another object.	Eliminate cause of reflection.	
	1. Connectors between the electronic unit and solenoid are disconnected.	Connect the electronic unit connectors to the solenoid.	
		2. Debris or scale in solenoid.	Unscrew solenoid, pull out the plunger and the spring from the solenoid and clean them. Use scale remover material if needed. When replacing the plunger, please make sure that the spring is in vertical position.
	3. The central orifice in the diaphragm is plugged or the diaphragm is torn		Clean the orifice or replace diaphragm.
	4. The water supply pressure is higher than 8 bar.		Reduce the supply water pressure.
Water flow from spout does not stop:	1. Sensor flashes once when user's hands are within the sensor's range.	Debris or scale in diaphragm	Clean the orifice or replace diaphragm.
			2. LED in the sensor does not flash once when user's hands are within the sensor's range.
		2. Sensor is picking up reflections from the washbasin or another object.	Decrease the range or eliminate cause of reflection.
Water flow diminished		Filter or aerator is clogged	Remove, clean, re-install

* "Security Mode": If the sensor is covered for more than 90 sec. the faucet will automatically shut off water flow. To return to normal operation remove any blockage.

** In this case, the water flow will stop anyway after 90 seconds because of the security time.